



 **FIRBIMATIC**

F18 F25 AS

**ALTERNATIVE
SOLVENTS**



L'estensione della serie con due nuovi progetti, rappresentano l'applicazione di tutte le evoluzioni tecnologiche di questo nuovo millennio, sottolineando ulteriormente il carattere innovativo che contraddistingue la FIRBIMATIC.

F18-F25 AS si aggiungono alla ricca gamma FIRBIMATIC con nuove soluzioni in termini di:

IL RISPARMIO: la riduzione dei costi di gestione nei parametri di esercizio, ed in particolare quelli di energia, acqua e solvente.

L'ECOLOGIA: la serie F è il frutto dell'esperienza che ha caratterizzato questi ultimi anni, queste macchine sono in grado di offrire prestazioni, in termini di concentrazione di vapori di solvente all'interno macchina ampiamente al di sotto degli standard richiesti.

La SICUREZZA: ad ogni passo del ciclo di lavorazione le nostre macchine sono tenute sotto controllo dalla tecnologia FIRBIMATIC che garantisce la sicurezza dell'operatore e degli indumenti.

Questi gli obiettivi principali che offrono ai nostri clienti uno strumento di lavoro semplice, affidabile e soprattutto al passo coi tempi, e rendono piacevole il proprio lavoro giornaliero



The new models F18 and F25 AS represent the technological evolution of the F series in compliance with the project of further extending the current series with additional models, which represent at best the technological evolution and the usual innovation character of FIRBIMATIC.

F18-F25 AS are the newcomers in the rich production range Firbimatic, and bring more new solutions in terms of:

SAVINGS: reduction of running costs and optimization of utilities, with particular reference to energy, water, and solvent.

ECOLOGY: F18-F25 is the result the experience and heavy-duty operation of the F series in the last years, and have been designed and built to offer excellent performances in terms of concentrations of solvent vapors in the drum far below the required standards.

SAFETY: in every single cycle step the machines are fully monitored by the technology of Firbimatic and guarantee safe operation and best cleaning of garments.

Just facts in line with the mission to offer to our clients a simple way of work and especially reliable and up-to-date instruments, which make every day work easier and enjoyable.



Die neuen Modelle F18 und F25 repräsentieren die Anwendung aller technologischen Entwicklungen dieses neuen Jahrtausends und heben den innovativen Charakter der Firma FIRBIMATIC hervor.

Die Modelle **F18 und F25 AS** sind neue Modelle in der grossen Produktpalette der Firbimatic Reinigungsmaschinen und bringen zusätzliche neue Lösungen hinsichtlich:

EINSPARUNGEN: Reduzierung der Betriebskosten, hier insbesondere der Energie, des Wassers und dem Lösungsmittel.

ÖKOLOGIE: Die Reinigungsmaschinen F18 - F25 sind das Ergebnis der Erfahrung in der F-Serie aus den letzten Jahren. Sie wurden so entwickelt und gebaut für ausgezeichnete Leistungen betreffend die Konzentration der Lösemittel-Dämpfe in der Trommel, die weit unter der geforderten Standards sind.

SICHERHEIT: bei jedem Schritt des Bearbeitungszyklus sind die Maschinen von der Firbimatic-Technologie vollständig überwacht und gewährleisten so einen total sicheren Betrieb und beste Reinigung und Pflege der Bekleidung.

Unser Hauptziel ist, unseren Kunden ein einfaches, aber leistungsstarkes, Werkzeug zur Verfügung zu stellen, das zuverlässig und modern ist, um mit diesen Maschinen leichter und angenehmer sowie vorteilhafter zu arbeiten.



L'extension de la série « F » en ces deux nouveaux projets, représente l'application des toutes les évolutions technologiques de ce millénaire, en mettant en évidence les aspects toujours les plus innovatives marquées Firbimatic.

F18-F25 s'ajoutent à la riche gamme Firbimatic avec ces nouvelles caractéristiques :

ECONOMIE : la réduction des frais de gestion et de dépense d'eau, d'énergie et de solvant.

ÉCOLOGIE : la série « F » représente le résultat final de toute expérience acquise dans ces dernières années ; ces machines proposent beaucoup des performances comme, par exemple, une concentration de vapeur de solvant dans la machine beaucoup plus bas des standards prévues.

SÛRETÉ : les cycles de travail de nos machines sont bien contrôlés et supervisés par la technologie Firbimatic qui garantit la sûreté de l'opérateur et des tissus.

Ces sont les ambitions principales qui essaient de donner aux clients un outil de travail qui soit simple, fiable, moderne et surtout capable de rendre votre travail agréable.



La extensión de la serie con dos nuevos proyectos, representa la aplicación de todos los desarrollos tecnológicos de este nuevo milenio, resaltando aún más el carácter innovador que distingue a Firbimatic.

F18- F25 AS se sumarán a la rica gama de Firbimatic con nuevas soluciones en términos de:

AHORRO: reducir los costos de operación en los parámetros de funcionamiento, y en particular los de energía, agua y disolventes.

ECOLOGÍA: La serie F es el resultado de la experiencia que ha caracterizado los últimos años, estas máquinas son capaces de ofrecer beneficios en términos de vapor de disolvente concertada dentro de la máquina muy por debajo de los estándares requeridos.

SEGURIDAD: en cada paso del ciclo de procesamiento, nuestras máquinas son mantenidas bajo control por la tecnología Firbimatic garantizar la seguridad del operador y la ropa.

Estos son los objetivos principales que ofrecemos a nuestros clientes, un trabajo simple, fiable y duradero en el tiempo, y hacer agradable su trabajo diario.



新型号F18和F25预示着F系列干洗机技术上新的变革,将会在这个系列中扩展出更多型号的机器。这两个新型号的机器配备了FIRBIMATIC现有最佳的革新技术。F18和F25是FIRBIMATIC众多产品中的新成员,它们带来了更多新的解决方案:

节省开支: 减少了运行消耗并优化了共用资源,特别是能源,水和溶剂的消耗。

生态环保: F18和F25是基于近几年的生产制造和长时间操作的经验而改进出来的,它们出现是为了提供绝佳的清洗效果的同时也更注重环境的保护,在完成清洗循环后清洗舱内的溶剂蒸汽含量是大大低于欧盟标准要求的。

安全性: 在清洗循环中的每个步骤时,通过FIRBIMATIC的技术来完全监控整台机器的状态,并且确保操作的安全性和最好的清洗效果。



F25 AS



DATI TECNICI	TECHNICAL DATA	TECHNISCHEN DATEN	DONNEES TECHNIQUES	DATOS TECNICOS	技术参数:	50 Hz	60 Hz	F18 AS ST2	F18 AS LT2	F18 AS LT3	F25 AS ST2	F25 AS LT2	F25 AS LT3
CESTO	DRUM	TROMMEL	TAMBOUR	TAMBOR	滚筒								
Capacità di carico	Loading capacity	Kapazitaet	Capacité de charge	Capacidad de carga	洗涤容量	Kg.	Lbs	18	40	18	40	18	40
Volumi cesto	Basket volume	Volumen	Volume tambour	Volumen tambor	滚筒容积	Lt	UG	340	12	340	12	340	12
Diametro cesto	Basket diametre	Durchmesser	Diamètre tambour	Diametro tambor	滚筒直径	mm	in.	900	35,4	900	35,4	900	35,4
Profondità cesto	Basket depth	Tiefe	Profondeur tambour	Profundidad tambor	滚筒深度	mm	in.	535	21	535	21	535	21
Diametro bocca di carico	Door diametre	Durchmesser Tuer	Diamètre hublot	Diametro puerta de carga	门直径	mm	in.	500	20	500	20	500	20
Giri in lavaggio	Wash speed	Waschgeschwindigkeit	Vitesse lavage	Velocidad lavado	洗涤速度	RPM	RPM	20/50	20/50	20/50	20/50	20/50	20/50
Giri in centrifuga	Extract speed	Schleuder Geschwindigkeit	Vitesse essorage	Velocidad centrifuga	甩干速度	RPM	RPM	300/520	300/520	300/520	300/520	300/520	300/520
SERBATOI	TANKS	TANK	RESERVOIRS	TANQUES	溶剂缸								
Serbatoio 1	Tank 1	Tank 1	Réservoir 1	Tanque 1	溶剂缸 1	Lt	UG	118	31	118	31	118	31
Serbatoio 2	Tank 2	Tank 2	Réservoir 2	Tanque 2	溶剂缸 2	Lt	UG	118	31	118	31	118	31
Serbatoio 3	Tank 3	Tank 3	Réservoir 3	Tanque 3	溶剂缸 3	Lt	UG	-	-	-	-	160	42
DISTILLATORE	STILL	DESTILLATOR	DISTILLATEUR	DESTILADOR	蒸馏箱								
Volume utile	Useful volume	Fuellmenge normal	Volume utile	Volumen util	可用容积	Lt	UG	144	38	145	38,3	145	38,3
Volume totale	Total volume	Fuellmenge max	Volume totale	Volumen total	总容积	Lt	UG	164	43,3	180	47,3	180	47,6
FILTRO ECO	ECO FILTER	NYLON FILTER	FILTRE ECO	FILTRO ECO	生态过滤器								
Volume	Volume	Kapazitaet	Volume	Volumen	容积	Lt	UG	55	14,5	55	14,5	55	14,5
Superficie filtrante	Filtering surface	Flaeche	Surface filtre	Superficie filtrante	生态过滤器表面	m²	ft²	3,9	42	3,9	42	3,9	42
Dischi	Discs	Filterelement	Disques	Discos	盘片	nr	no.	26	26	26	26	26	26
FILTRO DECOLORANTE - PR	DECOLORANT FILTER - PR	KOHLEFILTER	FILTRE DECOLORATEUR	FILTRO DECOLORADOR	脱色过滤器								
Volume	Volume	Volumen	Volume	Volumen	容积	Lt	UG	25	6,6	25	6,6	25	6,6
Tubi	Tubes	Rohrgroesse	Tubes	Tubos	过滤管	nr	no.	1	1	1	1	1	1
Cartucce	Cartridges	Kartuschengroesse	Cartouches	Cartuchos	滤芯	nr	no.	2	2	2	2	2	2
FILTRO CARTUCCIA - KR	DUAL CARTRIDGE FILTER - KR	KR-KARTUSCHENFILTER	FILTRE CARTOUCHE - KR	FILTRO DE CARTUCHO - KR	滤芯式过滤器								
Volume	Volume	Volumen	Volume	Volumen	容积	Lt	UG	55	14,5	55	14,5	55	14,5
Tubi	Tubes	Rohrgroesse	Tubes	Tubos	过滤管	nr	no.	1	1	1	1	1	1
Cartucce	Cartridges	Kartuschengroesse	Cartouches	Cartuchos	滤芯	nr	no.	2	2	2	2	2	2
POTENZE ELETTRICHE	POWER	ANSCHLUSSWERTE	PUISSANCES ELECTRIQUES	POTENCIAS	功率								
Versione elettrica	Electric version	Elektrisch beheizt	Version électrique	Version electrica	电加热版	kW	kW	24,5	25,5	24,5	25,5	24,5	25,5
Versione vapore	Steam version	Fremddampfbeheizt	Version vapeur	Version vapor	蒸汽加热版	kW	kW	8	8	8	8	8	8
Motore lavaggio/centrifuga	Main motor	Hauptmotor	Moteur lavage/essorage	Motor lavado/centrifuga	主电机	kW	kW	1,3÷3,5	1,3÷3,5	1,3÷3,5	1,3÷3,5	1,3÷3,5	1,3÷3,5
Pompa solvente	Solvent pump	Loesemittelpumpe	Pompe solvant	Bomba disolvente	溶剂泵	kW	kW	0,75	0,75	0,75	0,75	0,75	0,75
Motore ventilatore	Fan motor	Ventilatormotor	Moteur ventilateur	Motor ventilator	风机马达	kW	kW	1,5	2,65	1,5	2,65	1,5	2,65
Compressore gruppo frigorifero	Refrigeration compressor	Kuehlung	Compresseur groupe frigo	Compresor grupo de frio	制冷压缩机	kW	kW	3,75	3,75	3,75	3,75	3,75	3,75
Motore filtro ECO	ECO filter motor	ECO Filter motor	Moteur filtre ECO	Motor filtro ECO	生态过滤器马达	kW	kW	0,55	0,55	0,55	0,55	0,55	0,55
Compressore aria	Air compressor	Luft Kompressor	Compresseur air	Compresor de aire	空气压缩机	kW	kW	0,38	0,38	0,38	0,38	0,38	0,38
Pompa vuoto	Vacuum pump	Vaakum pumpe	Pompe à vide	Bomba vacío	空气压缩机	kW	kW	0,38	0,38	0,38	0,38	0,38	0,38
Resistenze asciug. (vers.eletr.)	Drying heaters (electric version)	Heizstäbe der Heizung (Elektrisch V)	Resistances séchage (vers.élect.)	Resisten. secado (vers.elect.)	加热烘干 (电加热版)	kW	kW	9	9	9	9	9	9
Resistenze distillat. (vers.eletr.)	Still elements (electric version)	Heizstäbe der Destillier (Elektrisch V)	Résistances distillat.(vers.élect.)	Resistencia destil.(vers.elect.)	蒸汽接口	kW	kW	7,5	7,5	7,5	7,5	7,5	7,5
COLLEGAMENTI	CONNECTIONS	ANSCHLUSS	CONNECTIONS	CONEXIONES	管道接口								
Aria	Air compressor	Luft	Entrée air	Entrada aire	空气压缩机	Ø	Ø	1/4"	1/4"	1/4"	1/4"	1/4"	1/4"
Acqua	Water	Wasser	Entrée eau	Entrada agua	水接口	Ø	Ø	3/4"	3/4"	3/4"	3/4"	3/4"	3/4"
Vapore	Steam	Dampf	Entrée vapeur	Entrada vapor	蒸汽接口	Ø	Ø	1/2"	1/2"	1/2"	1/2"	1/2"	1/2"
PESO	WEIGHT	GEWICHT	POIDS	PESO	重量								
A vuoto	Empty	Netto	A vide	En vacío	机器净重	Kg.	Lbs	1540	3395	1650	3634	1680	3704
Con solvente	With solvent	Mit Loesemittel	Avec solvant	Con disolvente	带溶剂重量	Kg.	Lbs	1813	3997	1935	4266	2114	4661
Carico statico con solvente	Static load with solvent	Statische Belastung mit Loesemittel	Charge statique avec solvant	Carga estatica con disolvente	带溶剂静荷载	Kg/m²	Lbs/m²	687	141	717	147	783	160
Carico dinamico (+10%)	Dynamic load (+10%)	Dinamische Belastung (+10%)	Charge dynamique (+10)	Carga dinamica (+10%)	动荷载 (+10%)	Kg/m²	Lbs/m²	1068	219	1095	224	1167	239
DIMENSIONI	DIMENSIONS	ABMESSUNGEN	DIMENSIONS	DIMENSIONES	机器尺寸								
Larghezza	Width	Hoehle	Largeur	Ancho	宽	mm	in.	1200+154	47,2+3	1800+154	70,9+3	1800+154	70,9+3
Profondità	Depth	Breite	Profondeur	Profundidad	深	mm	in.	2300	90,6	1650	65	1650	65
Altezza	Height	Tiefe	Hauteur	Altura	高	mm	in.	2140	84,3	2140	84,3	2140	84,3

La ditta si riserva di cambiare le specifiche senza preavviso

All specifications are subject to change without notice

Die technischen Daten kann ohne Voranzeige gewechselt werden

Toutes spécifications peuvent changer sans notification

Todas especificaciones pueden cambiar sin preaviso

若有参数变化, 恕不另行通知



F18-F25 AS
PARLIAMO CON I FATTI
JUST FACTS
NUR FAKTEN
LES FAITS PARLENT CLAIR
HABLANDO CON LOS HECHOS



F18 AS ST2



F18 AS LT3



F25 AS LT3

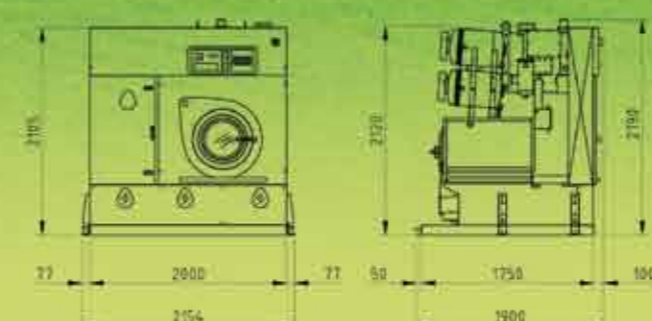
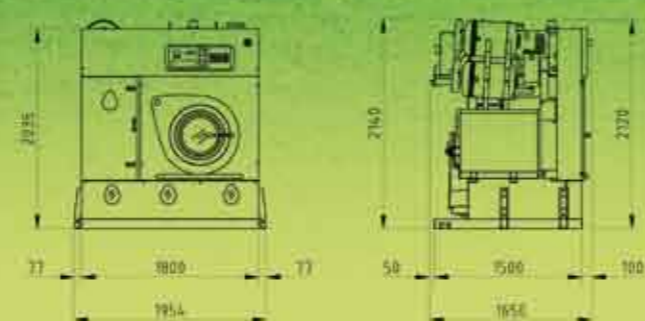
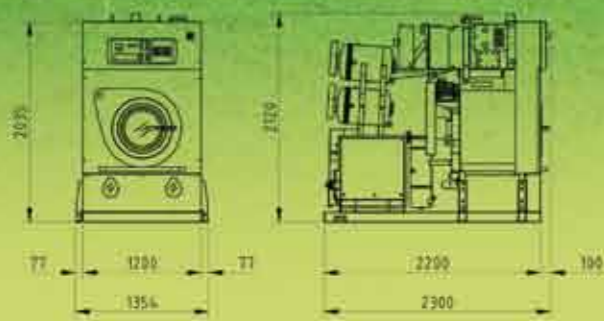

F25 AS

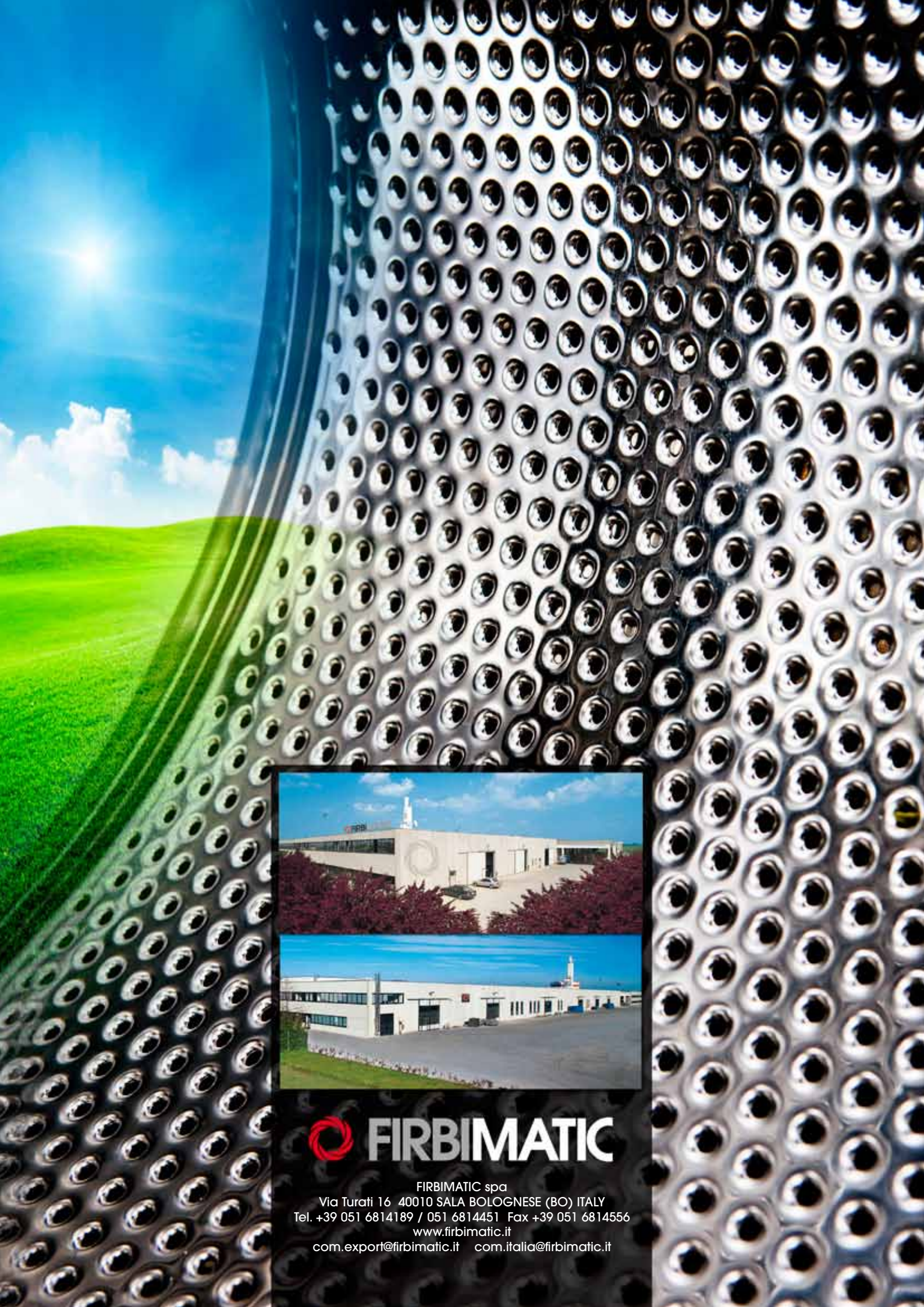

FIRBIMATIC

FIRBIMATIC spa
Via Turati 16 40010 SALA BOLOGNESE (BO) ITALY
Tel. +39 051 6814189 / 051 6814451 Fax +39 051 6814556
www.firbimatic.it
com.export@firbimatic.it com.italia@firbimatic.it